

Diamantschleifinstrumente • Diamond Grinding Instruments • Fraises diamantées de laboratoire

Labor • Laboratory • Laboratoire

801
(001)
Rund
Round
Ronde

| | | | | | | | | | | |
|--|------------|------------|------------|------------|------------|------------|------------|------------|------------|------------|
| Größe/Size/Taille \varnothing 1/10 mm | 009 | 010 | 012 | 014 | 016 | 018 | 021 | 023 | 029 | 035 |
| Länge-Length in mm - Longueur | | | | | | | | | | |
| Shank ISO REF 5 | | | | | | | | | | |
| HP 806 104 001 524 ... 801 - ... M - HP | 009 | 010 | 012 | 014 | 016 | 018 | 021 | 023 | 029 | 035 |

opt. 30.000 rpm, > 023-035 20.000 rpm



801-010M-HP

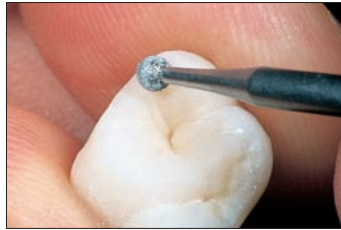

801-021M-HP



805-014M-HP

805
(010)
Umgekehrter Kegel
Inverted Cone
Cône renversé

| | | | | | | | | |
|--|------------|------------|------------|------------|------------|------------|------------|------------|
| Größe/Size/Taille \varnothing 1/10 mm | 012 | 014 | 016 | 018 | 021 | 023 | 040 | 050 |
| Länge-Length in mm - Longueur | 1,5 | 1,5 | 1,5 | 1,5 | 2,0 | 2,0 | 1,5 | 2,0 |
| Shank ISO REF 5 | | | | | | | | |
| HP 806 104 010 524 ... 805 - ... M - HP | 012 | 014 | 016 | 018 | 021 | 023 | 040 | 050 |

opt. 40.000 rpm, > 023-035 30.000 rpm, > 035 20.000 rpm

807
(225)
Umgekehrter Kegel
Inverted Cone
Cône renversé

| | | | |
|--|------------|------------|------------|
| Größe/Size/Taille \varnothing 1/10 mm | 016 | 018 | 023 |
| Länge-Length in mm - Longueur | 4,0 | 5,0 | 6,0 |
| Shank ISO REF 5 | | | |
| HP 806 104 225 524 ... 807 - ... M - HP | 016 | 018 | 023 |

opt. 30.000 rpm

808
(014)
Umgekehrter Kegel
Inverted Cone
Cône renversé

| | | |
|--|------------|------------|
| Größe/Size/Taille \varnothing 1/10 mm | 018 | 023 |
| Länge-Length in mm - Longueur | 0,7 | 0,8 |
| Shank ISO REF 5 | | |
| HP 806 104 014 524 ... 808 - ... M - HP | 018 | 023 |

opt. 30.000 rpm

809
(019)
mit Ansatz
with Collar
avec extension

| | |
|--|------------|
| Größe/Size/Taille \varnothing 1/10 mm | 023 |
| Länge-Length in mm - Longueur | 3,5 |
| Shank ISO REF 5 | |
| HP 806 104 019 524 ... 809 - ... M - HP | 023 |

opt. 30.000 rpm

Bitte Drehzahlbereiche beachten (Drehzahltable - Seite 11.14) / Please observe Recommended speeds (speed chart - page 11.14) / Respecter les vitesses de rotation recommandées (voir à la page 11.14)

| | | | | |
|-----------|---------------------------------------|---------------------------------|------------------|-------------|
| F | Roter Ring/Red ring/Bague rouge | Fein/Fine/Fin | 50 μ m | ISO No. 514 |
| M | Ohne Ring/Without ring/Sans bague | Standard/Standard/Standard | 110 -120 μ m | ISO No. 524 |
| C | Grüner Ring/Green ring/Bague verte | Grob/Coarse/Gros | 135 μ m | ISO No. 534 |
| SC | Schwarzer Ring/Black ring/Bague noire | Supergrob/Supercourse/Supergros | 180 μ m | ISO No. 544 |

Diamantschleifinstrumente • Diamond Grinding Instruments • Fraises diamantées de laboratoire

812
(022)
Umgekehrter Kegel, Seite schneidend
Inverted Cone, Side cutting
Cône renversé, bout lisse



seitenbelegt
side-coated
Sur les faces latérales

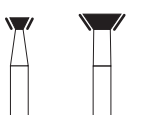

| | | |
|---|-----|-----|
| Größe/Size/Taille \varnothing 1/10 mm | 025 | 050 |
| Länge-Length in mm - Longueur | 1,5 | 2,0 |

Shank

HP 806 104 022 524 ... **812 - ... M - HP** **025** **050**

opt. 20.000 rpm

825
(304)
Linse
Knife Edge
Lentille

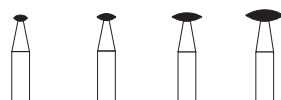

| | | | | |
|---|-----|-----|-----|-----|
| Größe/Size/Taille \varnothing 1/10 mm | 018 | 025 | 040 | 050 |
| Länge-Length in mm - Longueur | 0,8 | 0,9 | 1,1 | 1,5 |

Shank

HP 806 104 304 524 ... **825 - ... M - HP** **018** **025** **040** **050**

opt. -018 30.000 rpm, > -023 20.000 rpm

830
(238)
Birne
Pear
Poire



| | |
|---|------|
| Größe/Size/Taille \varnothing 1/10 mm | 070 |
| Länge-Length in mm - Longueur | 12,5 |

Shank

HP 806 104 238 544 ... **830 - ... SC - HP** **070**

opt. 15.000 rpm

835
(109)
Zylinder
Flat End Cylinder
Cylindre à bout plat



| | | | | | | |
|---|-----|-----|-----|-----|-----|-----|
| Größe/Size/Taille \varnothing 1/10 mm | 008 | 010 | 012 | 016 | 021 | 025 |
| Länge-Length in mm - Longueur | 4,0 | 4,0 | 4,0 | 4,0 | 5,0 | 6,0 |

Shank

HP 806 104 109 524 ... **835 - ... M - HP** **008** **010** **012** **016** **021** **025**

opt. 30.000 rpm, 025 20.000 rpm

837
(111)
Zylinder
Flat End Cylinder
Cylindre à bout plat

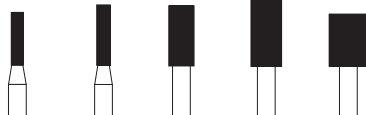

| | | | | | |
|---|-----|-----|-----|-----|-----|
| Größe/Size/Taille \varnothing 1/10 mm | 016 | 018 | 033 | 040 | 050 |
| Länge-Length in mm - Longueur | 7,0 | 8,0 | 8,0 | 9,0 | 7,0 |

Shank

HP 806 104 111 524 ... **837 - ... M - HP** **016** **018** **033** **040** **050**

opt. 30.000 rpm, > 023 20.000 rpm

Bitte Drehzahlbereiche beachten (Drehzahltable - Seite 11.14) / Please observe Recommended speeds (speed chart - page 11.14) / Respecter les vitesses de rotation recommandées (voir à la page 11.14)

| | | | | |
|-----------|---------------------------------------|---------------------------------|-----------------|-------------|
| F | Roter Ring/Red ring/Bague rouge | Fein/Fine/Fin | 50 μ m | ISO No. 514 |
| M | Ohne Ring/Without ring/Sans bague | Standard/Standard/Standard | 110-120 μ m | ISO No. 524 |
| C | Grüner Ring/Green ring/Bague verte | Grob/Coarse/Gros | 135 μ m | ISO No. 534 |
| SC | Schwarzer Ring/Black ring/Bague noire | Supergrob/Supercourse/Supergros | 180 μ m | ISO No. 544 |

Diamantschleifinstrumente • Diamond Grinding Instruments • Fraises diamantées de laboratoire

Labor • Laboratory • Laboratoire

842R
(143)

Zylinder, rund
Round Cylinder
Cylindre rond



| | |
|---|------|
| Größe/Size/Taille \varnothing 1/10 mm | 018 |
| Länge-Length in mm - Longueur | 12,0 |

| | | | |
|-------------------|---------------------|--------------------------|------------|
| Shank | ISO | REF | 5 |
| HP | 806 104 143 524 ... | 842R - ... M - HP | 018 |
| HP | 806 104 143 534 ... | 842R - ... C - HP | 018 |
| ⌚ opt. 30.000 rpm | | | |

845
(170)

Konus
Flat End Taper
Cône à bout plat

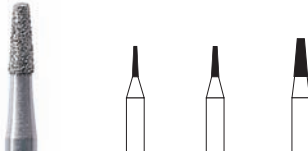

| | | | |
|---|-----|-----|-----|
| Größe/Size/Taille \varnothing 1/10 mm | 008 | 010 | 018 |
| Länge-Length in mm - Longueur | 4,0 | 4,0 | 5,0 |

| | | | |
|-------------------|---------------------|-------------------------|--------------------|
| Shank | ISO | REF | 5 |
| HP | 806 104 170 524 ... | 845 - ... M - HP | 008 010 018 |
| ⌚ opt. 30.000 rpm | | | |

847
(172)

Konus, flach
Flat End Taper
Cylindre à bout plat

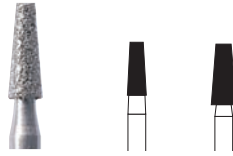

| | | |
|---|-----|-----|
| Größe/Size/Taille \varnothing 1/10 mm | 025 | 033 |
| Länge-Length in mm - Longueur | 7,0 | 8,0 |

| | | | |
|-------------------|---------------------|-------------------------|----------------|
| Shank | ISO | REF | 1 |
| HP | 806 104 172 524 ... | 847 - ... M - HP | 025 033 |
| ⌚ opt. 20.000 rpm | | | |

848A
(184)

Konus, Seite schneidend
Side Cutting Taper
Cône à bout lisse



| | |
|---|-----|
| Größe/Size/Taille \varnothing 1/10 mm | 040 |
| Länge-Length in mm - Longueur | 9,0 |

| | | | |
|-------------------|---------------------|--------------------------|------------|
| Shank | ISO | REF | 1 |
| HP | 806 104 184 524 ... | 848A - ... M - HP | 040 |
| ⌚ opt. 20.000 rpm | | | |

849
(196)

Konus, rund
Round End Taper
Cône rond



| | |
|---|-----|
| Größe/Size/Taille \varnothing 1/10 mm | 009 |
| Länge-Length in mm - Longueur | 4,0 |

| | | | |
|-------------------|---------------------|-------------------------|------------|
| Shank | ISO | REF | 5 |
| HP | 806 104 196 524 ... | 849 - ... M - HP | 009 |
| ⌚ opt. 30.000 rpm | | | |

842KR
(158)

Zylinder, Kante rund
KR Cylinder, Modified Shoulder
Cylindre bout arrondi



| | |
|---|------|
| Größe/Size/Taille \varnothing 1/10 mm | 023 |
| Länge-Length in mm - Longueur | 15,0 |

| | | | |
|-------------------|---------------------|---------------------------|------------|
| Shank | ISO | REF | 5 |
| HP | 806 104 158 534 ... | 842KR - ... C - HP | 023 |
| ⌚ opt. 30.000 rpm | | | |

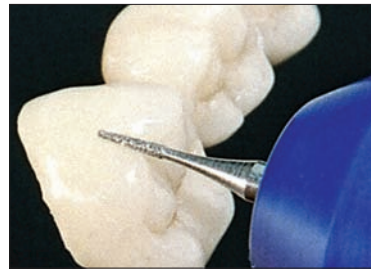

845-008M-HP

848
(173)

Konus, flach
Flat End Taper
Cylindre à bout plat



| | | |
|---|------|-----|
| Größe/Size/Taille \varnothing 1/10 mm | 018 | 040 |
| Länge-Length in mm - Longueur | 10,0 | 9,0 |

| | | | | |
|-------------------------------------|---------------------|-------------------------|----------------|---|
| Shank | ISO | REF | 5 | 1 |
| HP | 806 104 173 524 ... | 848 - ... M - HP | 018 040 | |
| HP | 806 104 173 534 ... | 848 - ... C - HP | 018 | |
| ⌚ opt. 30.000 rpm, > 035 20.000 rpm | | | | |

848L
(175)

Konus, lang, rund
Long Flat End Taper
Cône long



| | |
|---|------|
| Größe/Size/Taille \varnothing 1/10 mm | 023 |
| Länge-Length in mm - Longueur | 15,0 |

| | | | |
|-------------------|---------------------|---------------------------|------------|
| Shank | ISO | REF | 5 |
| HP | 806 104 175 534 ... | 848L - ... C - HP | 023 |
| HP | 806 104 175 544 ... | 848L - ... SC - HP | 023 |
| ⌚ opt. 30.000 rpm | | | |

Bitte Drehzahlbereiche beachten (Drehzahltable - Seite 11.14) / Please observe Recommended speeds (speed chart - page 11.14) / Respecter les vitesses de rotation recommandées (voir à la page 11.14)

| | | | | |
|--|---------------------------------------|---------------------------------|-----------------|-------------|
| ■ F | Roter Ring/Red ring/Bague rouge | Fein/Fine/Fin | 50 μ m | ISO No. 514 |
| ■ M | Ohne Ring/Without ring/Sans bague | Standard/Standard/Standard | 110-120 μ m | ISO No. 524 |
| ■ C | Grüner Ring/Green ring/Bague verte | Grob/Coarse/Gros | 135 μ m | ISO No. 534 |
| ■ SC | Schwarzer Ring/Black ring/Bague noire | Supergrob/Supercourse/Supergros | 180 μ m | ISO No. 544 |

Diamantschleifinstrumente • Diamond Grinding Instruments • Fraises diamantées de laboratoire

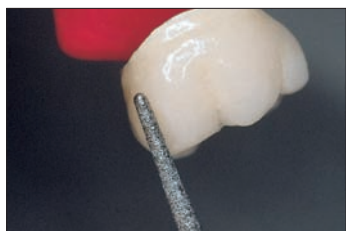

850-014M-HP



856-025M-HP

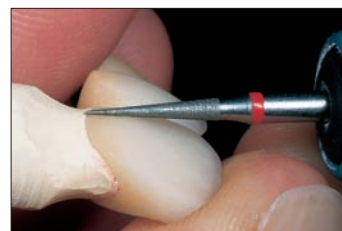

859-018F-HP

Labor • Laboratory • Laboratoire

850
(199)

Konus, rund
Round End Taper
Cône rond

| | | | | |
|---|------|------|------|-----|
| Größe/Size/Taille \varnothing 1/10 mm | 014 | 016 | 025 | 040 |
| Länge-Length in mm - Longueur | 10,0 | 10,0 | 10,0 | 9,0 |

Shank

| | | | | | |
|-------------------------|-------------------------|------------|------------|------------|------------|
| HP 806 104 199 524 ... | 850 - ... M - HP | 014 | 016 | 025 | 040 |
| HP 806 104 199 524 ... | 850 - ... C - HP | | | 025 | |

opt. 30.000 rpm, -040 20.000 rpm

854
(172)

Konus, flach
Flat End Taper
Cône à bout plat

| | |
|---|-----|
| Größe/Size/Taille \varnothing 1/10 mm | 050 |
| Länge-Length in mm - Longueur | 8,0 |

Shank

| | | |
|------------------------|-------------------------|------------|
| HP 806 104 172 524 ... | 854 - ... M - HP | 050 |
|------------------------|-------------------------|------------|

opt. 20.000 rpm

852
(164)

Konus, spitz
X-mas Tree
Cône pointu

| | | | |
|---|-----|-----|-----|
| Größe/Size/Taille \varnothing 1/10 mm | 010 | 023 | 037 |
| Länge-Length in mm - Longueur | 4,0 | 6,0 | 7,0 |

Shank

| | | | | |
|------------------------|-------------------------|------------|------------|------------|
| HP 806 104 164 524 ... | 852 - ... M - HP | 010 | 023 | 037 |
|------------------------|-------------------------|------------|------------|------------|

opt. 30.000 rpm, > 035 20.000 rpm

854R
(198)

Konus, rund
Round End Taper
Cône rond

| | | |
|---|-----|-----|
| Größe/Size/Taille \varnothing 1/10 mm | 033 | 040 |
| Länge-Length in mm - Longueur | 9,0 | 9,0 |

Shank

| | | | |
|------------------------|--------------------------|------------|------------|
| HP 806 104 198 524 ... | 854R - ... M - HP | 033 | 040 |
|------------------------|--------------------------|------------|------------|

opt. 20.000 rpm

856
(198)

Konus, rund
Round End Taper
Cône rond

| | | | | |
|---|-----|------|-----|------|
| Größe/Size/Taille \varnothing 1/10 mm | 016 | 023 | 025 | 040 |
| Länge-Length in mm - Longueur | 7,0 | 12,0 | 8,0 | 14,0 |

Shank

| | | | | |
|-------------------------|--------------------------|------------|------------|--|
| HP 806 104 198 524 ... | 856 - ... M - HP | 016 | 025 | |
| HP 806 104 198 534 ... | 856 - ... C - HP | 023 | 040 | |
| HP 806 104 198 544 ... | 856 - ... SC - HP | 023 | 040 | |

opt. 30.000 rpm, > -023 20.000 rpm



856-025M-HP

858
(165)

Konus, spitz
Needle
Cône pointu

| | | |
|---|-----|-----|
| Größe/Size/Taille \varnothing 1/10 mm | 012 | 016 |
| Länge-Length in mm - Longueur | 8,0 | 8,0 |

Shank

| | | | |
|-------------------------|-------------------------|------------|------------|
| HP 806 104 165 514 ... | 858 - ... F - HP | 016 | |
| HP 806 104 165 524 ... | 858 - ... M - HP | 012 | 016 |

opt. 30.000 rpm

859
(166)

Konus, spitz
Needle
Cône pointu

| | |
|---|------|
| Größe/Size/Taille \varnothing 1/10 mm | 018 |
| Länge-Length in mm - Longueur | 10,0 |

Shank

| | | |
|-------------------------|-------------------------|------------|
| HP 806 104 166 514 ... | 859 - ... F - HP | 018 |
| HP 806 104 166 524 ... | 859 - ... M - HP | 018 |

opt. 30.000 rpm

Bitte Drehzahlbereiche beachten (Drehzahltable - Seite 11.14) / Please observe Recommended speeds (speed chart - page 11.14) / Respecter les vitesses de rotation recommandées (voir à la page 11.14)

| | | | | | |
|--|-----------|---------------------------------------|---------------------------------|------------------|-------------|
| | F | Roter Ring/Red ring/Bague rouge | Fein/Fine/Fin | 50 μ m | ISO No. 514 |
| | M | Ohne Ring/Without ring/Sans bague | Standard/Standard/Standard | 110 -120 μ m | ISO No. 524 |
| | C | Grüner Ring/Green ring/Bague verte | Grob/Coarse/Gros | 135 μ m | ISO No. 534 |
| | SC | Schwarzer Ring/Black ring/Bague noire | Supergrob/Supercourse/Supergros | 180 μ m | ISO No. 544 |

Diamantschleifinstrumente • Diamond Grinding Instruments • Fraises diamantées de laboratoire

Labor • Laboratory • Laboratoire

860
(247)
Flamme
Flame
Flamme

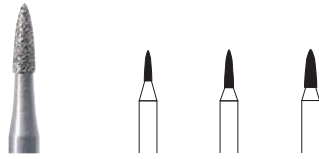

| | | | |
|-------------------------------|-------------------------|------------|-----------------------|
| Größe/Size/Taille ø 1/10 mm | 010 | 012 | 016 |
| Länge-Length in mm - Longueur | 4,0 | 5,0 | 5,0 |
| Shank ISO REF 5 | | | |
| HP 806 104 247 524 ... | 860 - ... M - HP | 010 | 012 016 |
| ⌚ opt. 30.000 rpm | | | |

860
(251)
Flamme
Flame
Flamme

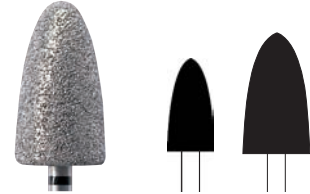

| | | |
|------------------------------------|--------------------------|-----------------------|
| Größe/Size/Taille ø 1/10 mm | 060 | 085 |
| Länge-Length in mm - Longueur | 12,5 | 16,0 |
| Shank ISO REF 1 | | |
| HP 806 104 251 544 ... | 860 - ... SC - HP | 060 085 |
| ⌚ opt. 20.000 rpm, -085 15.000 rpm | | |

861
(248)
Flamme
Flame
Flamme



| | |
|-------------------------------|------------------------------------|
| Größe/Size/Taille ø 1/10 mm | 014 |
| Länge-Length in mm - Longueur | 6,0 |
| Shank ISO REF 5 | |
| HP 806 104 248 524 ... | 861 - ... M - HP 014 |
| ⌚ opt. 30.000 rpm | |

861L
(250)
Flamme lang
Flame, long
Flamme long



| | |
|-------------------------------|-------------------------------------|
| Größe/Size/Taille ø 1/10 mm | 024 |
| Länge-Length in mm - Longueur | 10,0 |
| Shank ISO REF 1 | |
| HP 806 104 250 524 ... | 861L - ... M - HP 024 |
| ⌚ opt. 30.000 rpm | |

862
(274)
Flamme
Flame
Flamme



| | |
|-------------------------------|------------------------------------|
| Größe/Size/Taille ø 1/10 mm | 030 |
| Länge-Length in mm - Longueur | 8,0 |
| Shank ISO REF 1 | |
| HP 806 104 274 524 ... | 862 - ... M - HP 030 |
| ⌚ opt. 20.000 rpm | |

862
(274)
Flamme
Flame
Flamme



| | |
|-------------------------------|-------------------------------------|
| Größe/Size/Taille ø 1/10 mm | 060 |
| Länge-Length in mm - Longueur | 14,0 |
| Shank ISO REF 1 | |
| HP 806 104 274 544 ... | 862 - ... SC - HP 060 |
| ⌚ opt. 15.000 rpm | |

863
(250)
Flamme
Flame
Flamme



| | | |
|-------------------------------|---|------|
| Größe/Size/Taille ø 1/10 mm | 012 | 016 |
| Länge-Length in mm - Longueur | 10,0 | 10,0 |
| Shank ISO REF 5 | | |
| HP 806 104 250 524 ... | 863 - ... M - HP 012 016 | |
| HP 806 104 250 534 ... | 863 - ... C - HP 012 016 | |
| ⌚ opt. 30.000 rpm | | |

881
(141)
Zylinder, rund
Round End Cylinder
Cylindre à bout arrondi

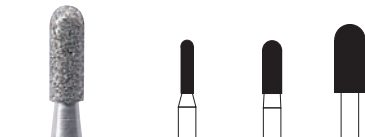

| | | | |
|--------------------------------------|--|-----|-----|
| Größe/Size/Taille ø 1/10 mm | 016 | 025 | 040 |
| Länge-Length in mm - Longueur | 7,0 | 7,0 | 9,0 |
| Shank ISO REF 5 1 | | | |
| HP 806 104 141 524 ... | 881 - ... M - HP 016 025 040 | | |
| ⌚ opt. 30.000 rpm, > -023 20.000 rpm | | | |

890
(245)
Granate
Grenade
Grenade

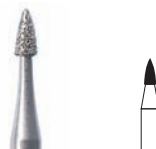

| | |
|-------------------------------|------------------------------------|
| Größe/Size/Taille ø 1/10 mm | 016 |
| Länge-Length in mm - Longueur | 3,5 |
| Shank ISO REF 5 | |
| HP 806 104 245 524 ... | 890 - ... M - HP 016 |
| ⌚ opt. 30.000 rpm | |

909
(068)
Reifen
Donut
Roue



| | |
|-------------------------------|------------------------------------|
| Größe/Size/Taille ø 1/10 mm | 050 |
| Länge-Length in mm - Longueur | 2,0 |
| Shank ISO REF 1 | |
| HP 806 104 068 524 ... | 909 - ... M - HP 050 |
| ⌚ opt. 20.000 rpm | |





Bitte Drehzahlbereiche beachten (Drehzahltable - Seite 11.14) / Please observe Recommended speeds (speed chart - page 11.14) / Respecter les vitesses de rotation recommandées (voir à la page 11.14)

| | | | | |
|--|---------------------------------------|---------------------------------|-------------|-------------|
| ■ F | Roter Ring/Red ring/Bague rouge | Fein/Fine/Fin | 50 µm | ISO No. 514 |
| ■ M | Ohne Ring/Without ring/Sans bague | Standard/Standard/Standard | 110 -120 µm | ISO No. 524 |
| ■ C | Grüner Ring/Green ring/Bague verte | Grob/Coarse/Gros | 135 µm | ISO No. 534 |
| ■ SC | Schwarzer Ring/Black ring/Bague noire | Supergrob/Supercourse/Supergros | 180 µm | ISO No. 544 |

Diamantschleifinstrumente • Diamond Grinding Instruments • Fraises diamantées de laboratoire

Labor • Laboratory • Laboratoire

366
(257)
Knospe
Pointed Football
Football pointu



| | | |
|---|-----|-----|
| Größe/Size/Taille \varnothing 1/10 mm | 012 | 016 |
| Länge- Length in mm - Longueur | 1,8 | 2,5 |

Shank **ISO** **REF** 5

HP ■ 806 104 257 524 ... **366 - ... M - HP** **012** **016**

⌚ opt. 30.000 rpm

368
(257)
Knospe
Pointed Football
Football pointu



| | | |
|---|-----|--|
| Größe/Size/Taille \varnothing 1/10 mm | 023 | |
| Länge- Length in mm - Longueur | 5,0 | |

Shank **ISO** **REF** 5

HP ■ 806 104 257 524 ... **368 - ... M - HP** **023**

⌚ opt. 30.000 rpm

369
(263)
Knospe, rund, schlank
Bud rounded slender
Football pointu, rond



| | |
|---|------|
| Größe/Size/Taille \varnothing 1/10 mm | 070 |
| Länge- Length in mm - Longueur | 12,0 |

Shank **ISO** **REF** 1

HP ■ 806 104 263 544 ... **369 - ... SC - HP** **070**

⌚ opt. 15.000 rpm

371
(266)
Knospe, rund, lang
Bud rounded long
Football pointu, rond, long

| | |
|---|------|
| Größe/Size/Taille \varnothing 1/10 mm | 055 |
| Länge- Length in mm - Longueur | 12,0 |

Shank **ISO** **REF** 1

HP ■ 806 104 266 524 ... **371 - ... M - HP** **055**

⌚ opt. 20.000 rpm

Perikymatienschleifer

Einfach in der Handhabung, genial in der Wirkung!

Mit dem TURBO Diamantinstrument entstehen die Perikymatien (Wachstumsrillen) in wenigen Sekunden. Das Instrument wird dabei wellenförmig über die Labialfläche geführt.

Perikymata Grinder

Easy to use with excellent results!

Perikymata are created in a few seconds using the TURBO diamond instrument. The instrument is moved over the labial surface in a wave-like motion.

Instrument pour structurer des périkymaties

Simple à manipuler, effet génial !



Avec cet instrument diamanté TURBO sont produites en quelques secondes les périkymaties (structures superficielles de croissance). L'instrument est passé sur la surface vestibulaire par un mouvement ondulatoire.



856-023TSC-HP



856
(200)
Konus, rund
Round End Taper
Cône rond



| | |
|---|------|
| Größe/Size/Taille \varnothing 1/10 mm | 023 |
| Länge- Length in mm - Longueur | 12,0 |

Shank **ISO** **REF** 5

HP ■ T806 104 200 544 ... **856 - ... TSC - HP** **023**

⌚ opt. 30.000 rpm

848L
(175)
Konus, lang
Long Flat End Taper
Cône long

| | |
|---|------|
| Größe/Size/Taille \varnothing 1/10 mm | 023 |
| Länge- Length in mm - Longueur | 15,0 |

Shank **ISO** **REF** 5

HP ■ T806 104 175 544 ... **848L - ... TSC - HP** **023**

⌚ opt. 30.000 rpm

Bitte Drehzahlbereiche beachten (Drehzahltable - Seite 11.14) / Please observe Recommended speeds (speed chart - page 11.14) / Respecter les vitesses de rotation recommandées (voir à la page 11.14)

| | | | | |
|-----------|---------------------------------------|---------------------------------|------------------|-------------|
| F | Roter Ring/Red ring/Bague rouge | Fein/Fine/Fin | 50 μ m | ISO No. 514 |
| M | Ohne Ring/Without ring/Sans bague | Standard/Standard/Standard | 110 -120 μ m | ISO No. 524 |
| C | Grüner Ring/Green ring/Bague verte | Grob/Coarse/Gros | 135 μ m | ISO No. 534 |
| SC | Schwarzer Ring/Black ring/Bague noire | Supergrob/Supercourse/Supergros | 180 μ m | ISO No. 544 |