





















## Hartmetallfräser • Tungsten Carbide Cutters • Fraises en carbure de tungstène

**SCE Kunststoff spezial / Kreuzverzahnung grob • Special acrylic Cutters/Coarse Cross Cut • Denture croisée grosse/pour des acryliques**

								
Größe/Size/Taille $\varnothing$ 1/10 mm	060	060	060	045	060	060	060	060
L mm	12,5	11,0	12,2	12,9	15,0	13,9		12,2
Shank 								
HP	500 104 ...	143 220 ...	237 220 ...	257 220 ...	200 220 ...	201 220 ...	274 220 ...	263 220 ...
 HF ...		<b>072SCE-060</b>	<b>077SCE-060</b>	<b>078SCE-060</b>	<b>079SCE-045</b>	<b>079SCE-060</b>	<b>251SCE-060</b>	<b>351SCE-060</b>

**SCN Einfachverzahnung grob • Coarse Plain Cut • Denture simple grosse**

					
Größe/Size/Taille $\varnothing$ 1/10 mm	060	045	060	060	060
L mm	12,2	12,9	15,0	13,9	
Shank 					
HP	500 104 ...	257 215 ...	200 215 ...	201 215 ...	274 215 ...
 HF ...		<b>078SCN-060</b>	<b>079SCN-045</b>	<b>079SCN-060</b>	<b>251SCN-060</b>

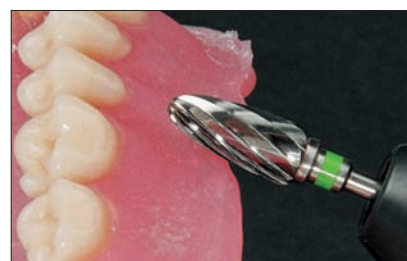









HF251SCN-060

**XCE Kunststoff - Fräser, Kreuzverzahnung supergrob Jumbo Plaster or Acrylic Cutters, Supercoarse Cross Cut Denture croisée supergrosse pour des acryliques**









HF251XCE-060

				
Größe/Size/Taille $\varnothing$ 1/10 mm	060	070	060	
L mm	12,5	14,2	13,9	
Shank 				
HP	500 104 ...	143 223 ...	263 223 ...	274 223 ...
 HF ...		<b>072XCE-060</b>	<b>351XCE-070</b>	<b>251XCE-060</b>

**XCN Einfachverzahnung supergrob Supercoarse Plain Cut Denture simple supergrosse**



HF251XCN-060

			
Größe/Size/Taille $\varnothing$ 1/10 mm		070	060
L mm		14,2	13,9
Shank 			
HP	500 104 ...	263 222 ...	274 222 ...
 HF ...		<b>351XCN-070</b>	<b>251XCN-060</b>